

Fiddle

Improvisation

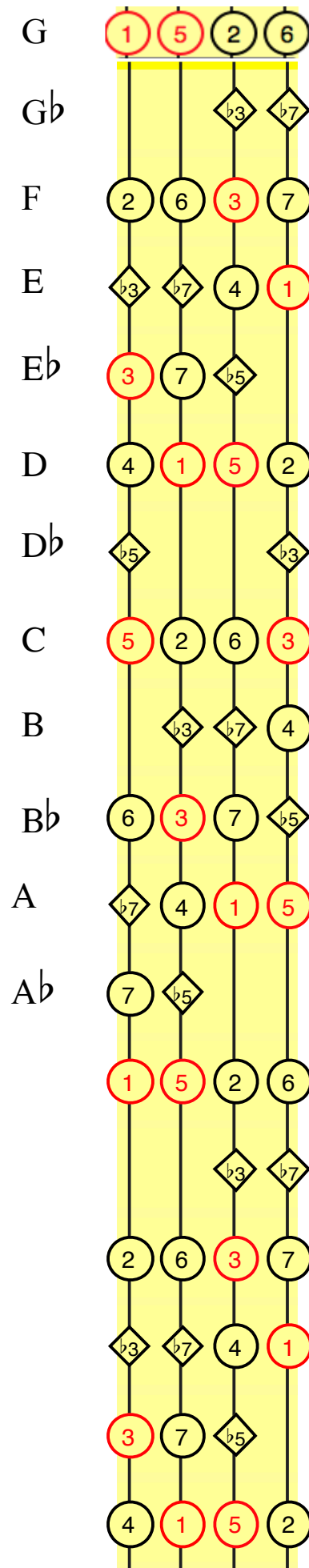

COMMON LICKS

1. slide from 2 to b3
2. slide up from 6 to 1
3. hammer on from 2 to 3
4. pull off from 3 to 2
5. hammer on from 5 to 6
6. pull off from 6 to 5
7. pull off from b3 to 2
8. boogie woogie on 5 and 6
9. add blues with b5 to 5
10. add blues with b5 to 4
11. add blues with b3 to 3
12. add blues with 6 to b7
13. add blues with b7 to 8
14. walk down 1 6 5 3
15. play intervals mandolin style
16. play harmonics
17. run up the scale (melodic)
18. run down the scale (melodic)
19. slur any minor pentatonic interval
20. bend the above when possible
21. sus4 and resolve
22. roll on numbers below
23. vamp on numbers below

1 chord = 1 3 5 *(b7)

4 chord = 1 4 6 (b3)

5 chord = 2 5 7 (4)

2 chord = 2 #4 6 (1)

b7 chord = b7 2 4

b3 chord = b3 5 b7

2m chord = 2 4 6 (1)

3m chord = 3 5 7 (2)

6m chord = 1 3 6 (5)

* = 7th chord

mmuussiiccaall
Rick Van Patten
Cincinnati, Ohio
2016